

Activity 3- Time to loft

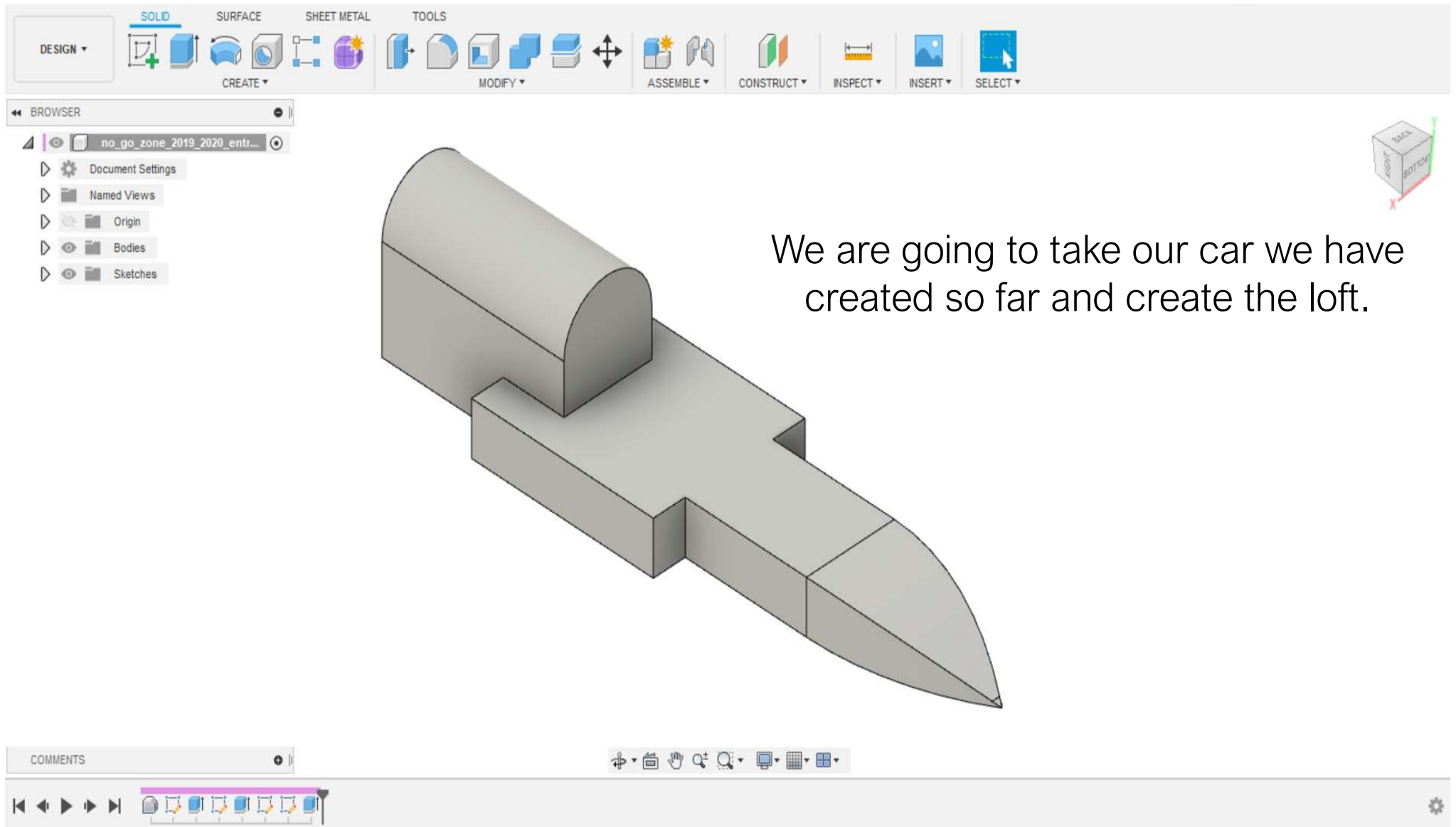



We are going to take our car we have created so far and create the loft.



BROWSER

- no_go_zone_2019_2020_ent...
- Document Settings
- Named Views
- Origin
- Bodies
- Sketches
- Construction

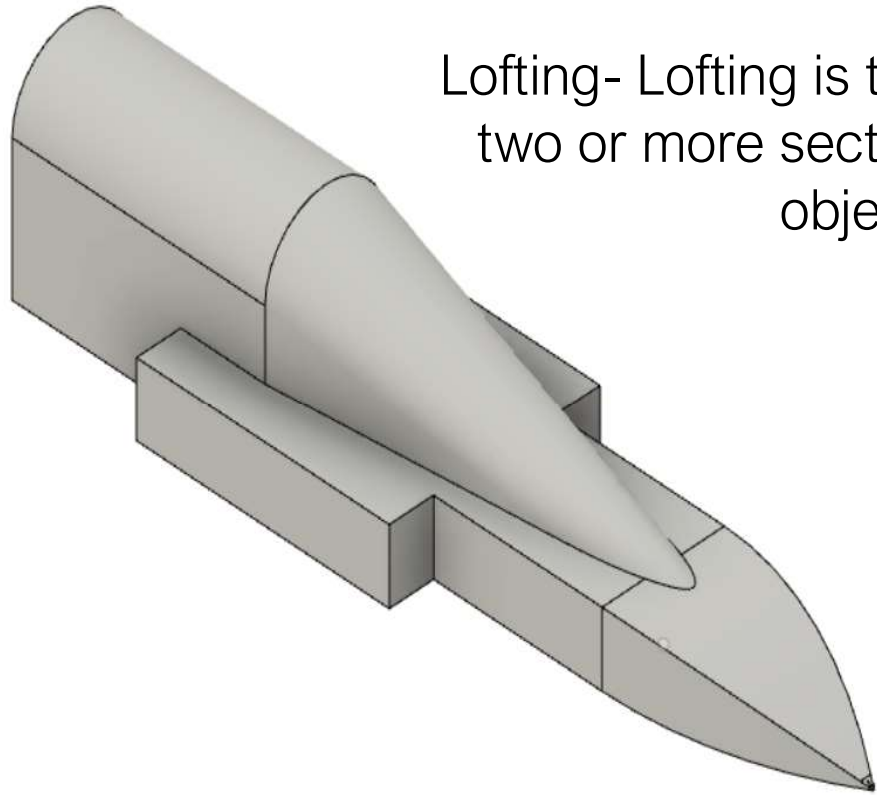

Lofting- Lofting is the tool which you can bring two or more sections together to result in a object or surface.



COMMENTS



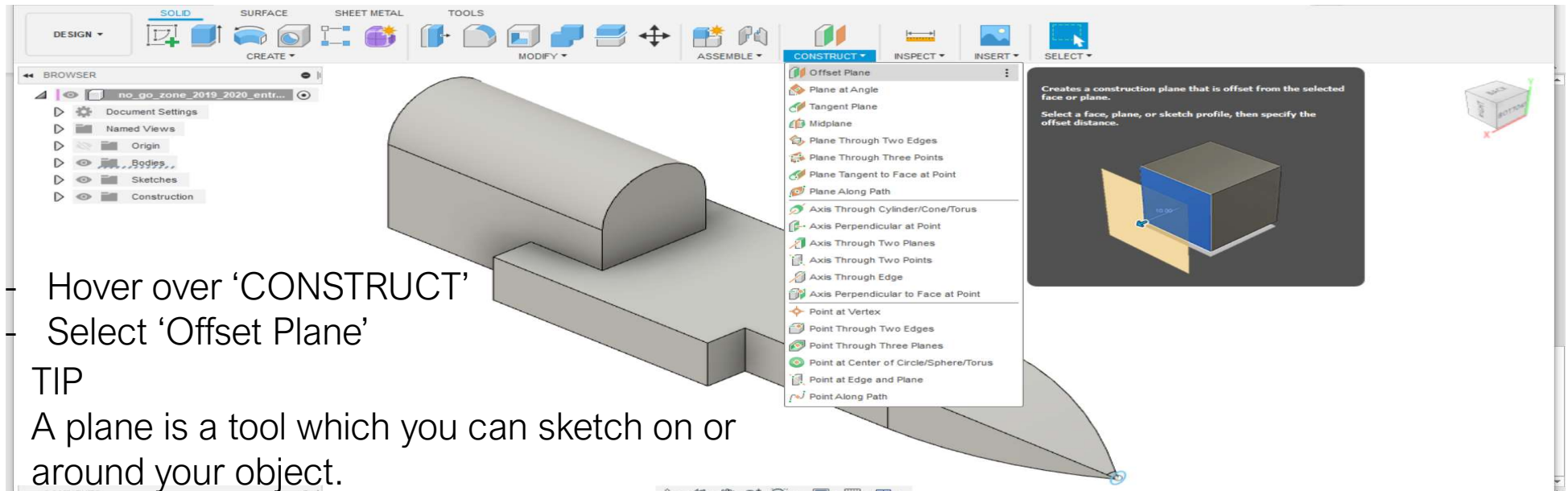

Hover over 'CONSTRUCT'
Select 'Offset Plane'

TIP

A plane is a tool which you can sketch on or around your object.

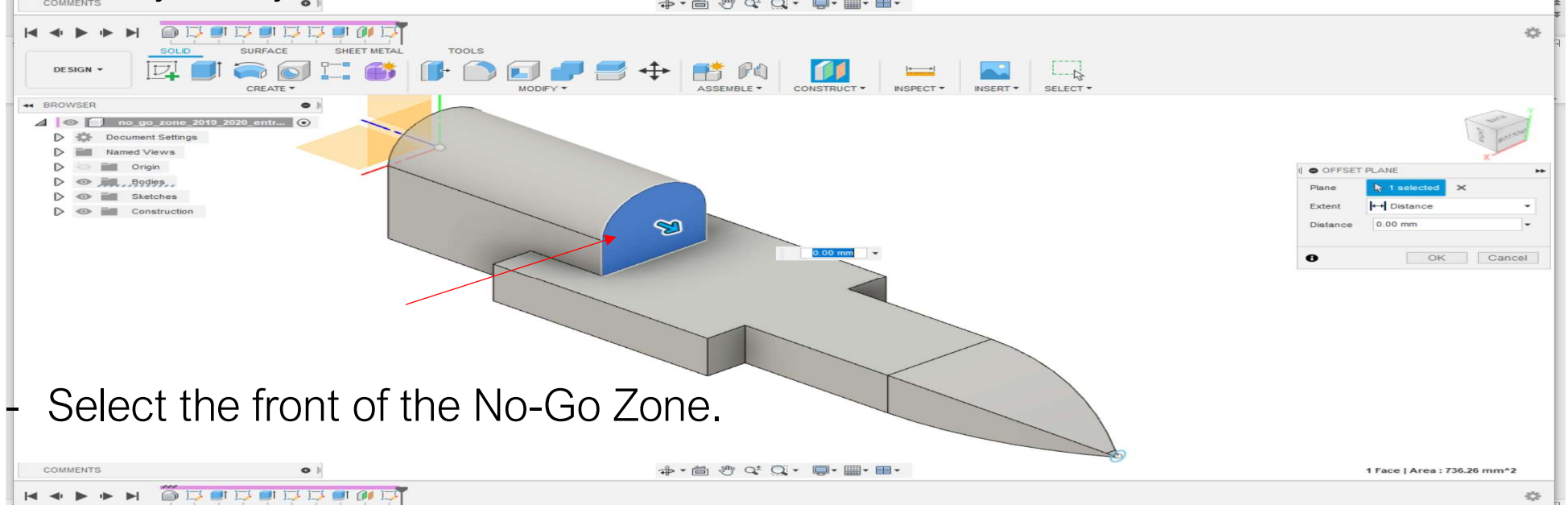

Select the front of the No-Go Zone.

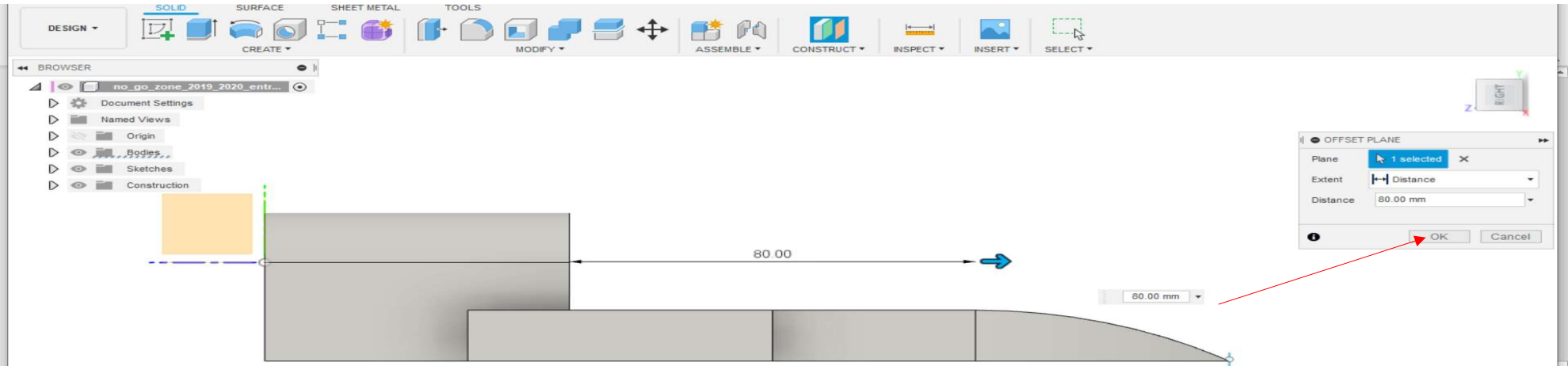

- Drag the blue arrow to the place you want your loft to end.
- Click 'OK' on the left menu.

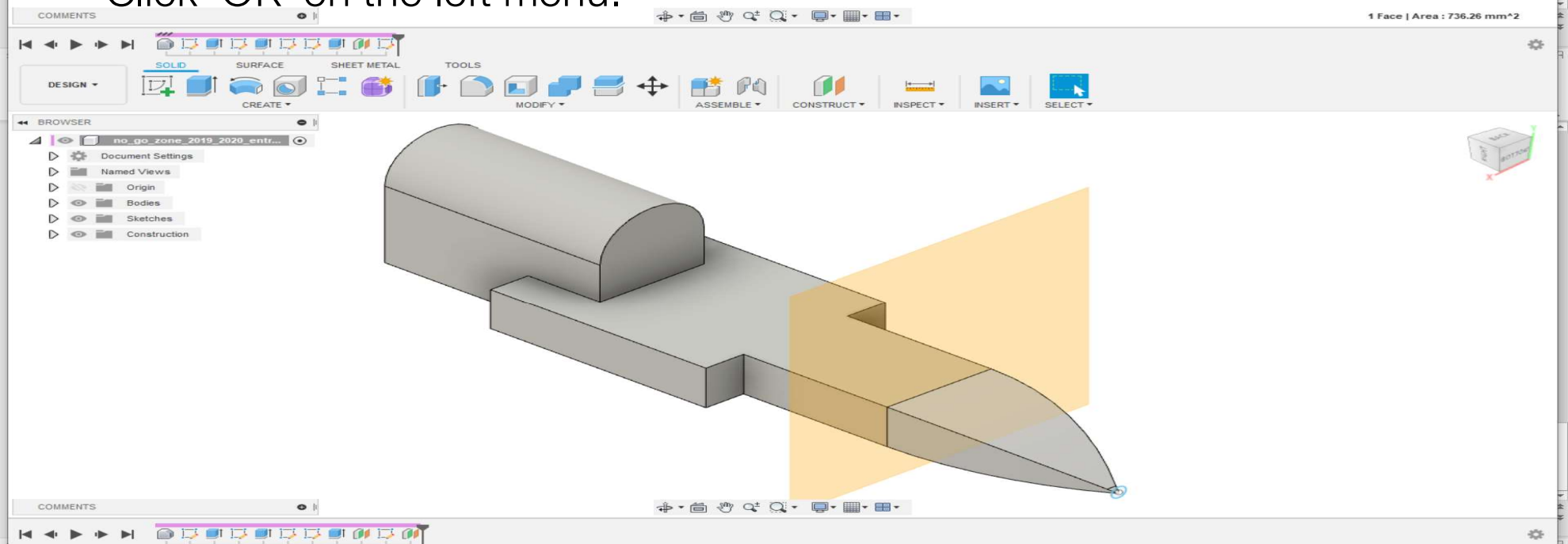

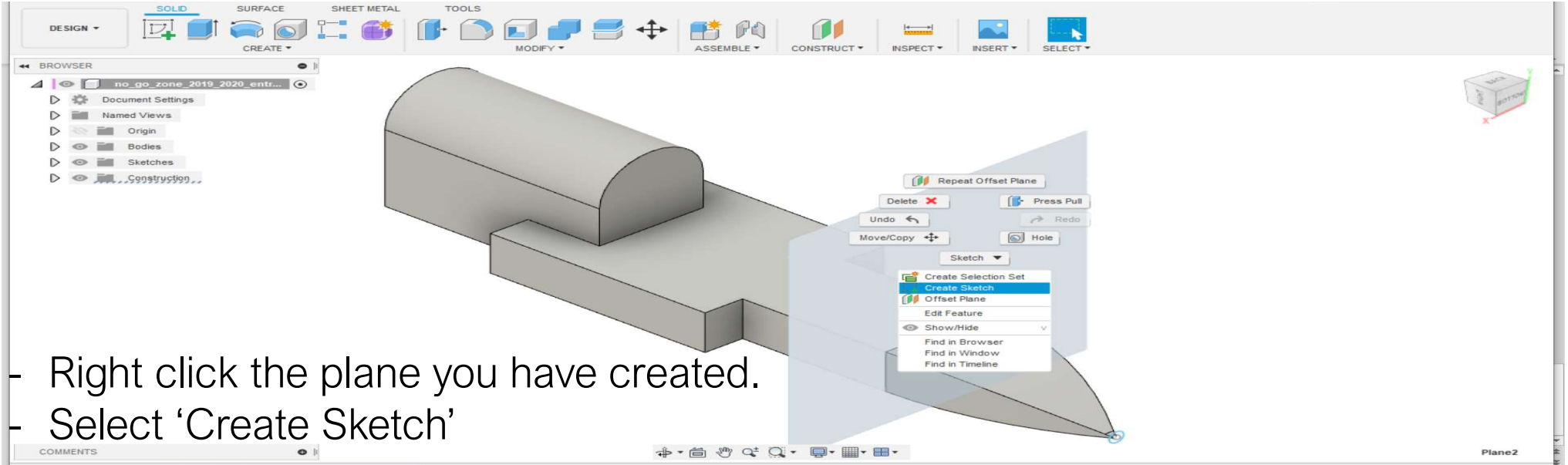

- Right click the plane you have created.
- Select 'Create Sketch'

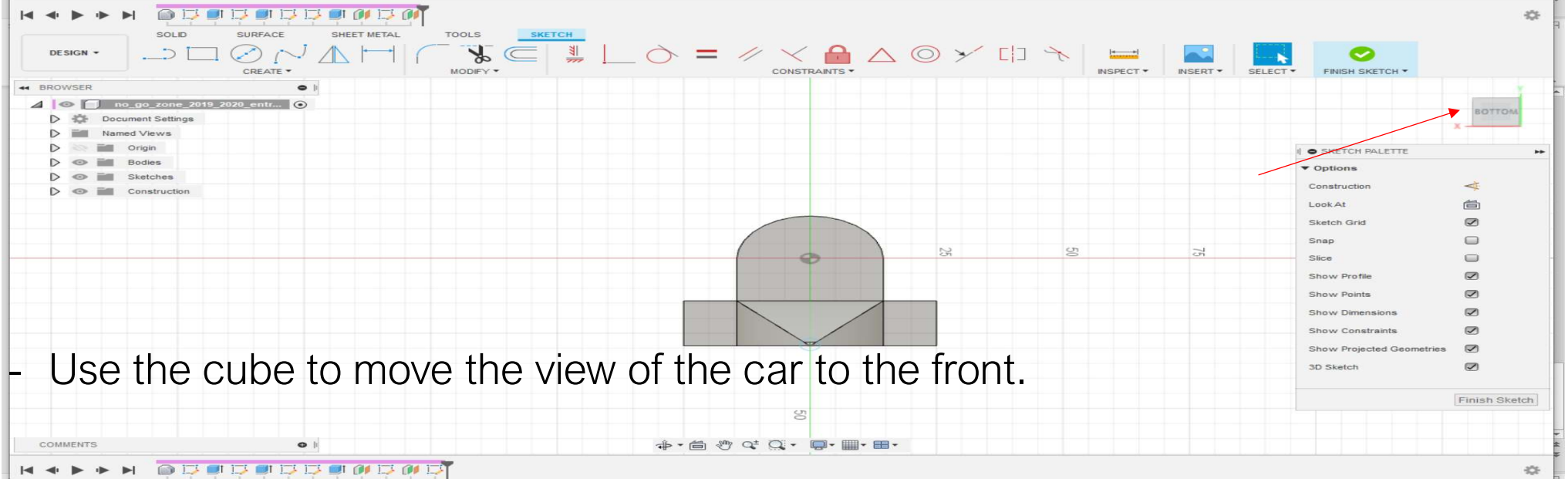

- Use the cube to move the view of the car to the front.

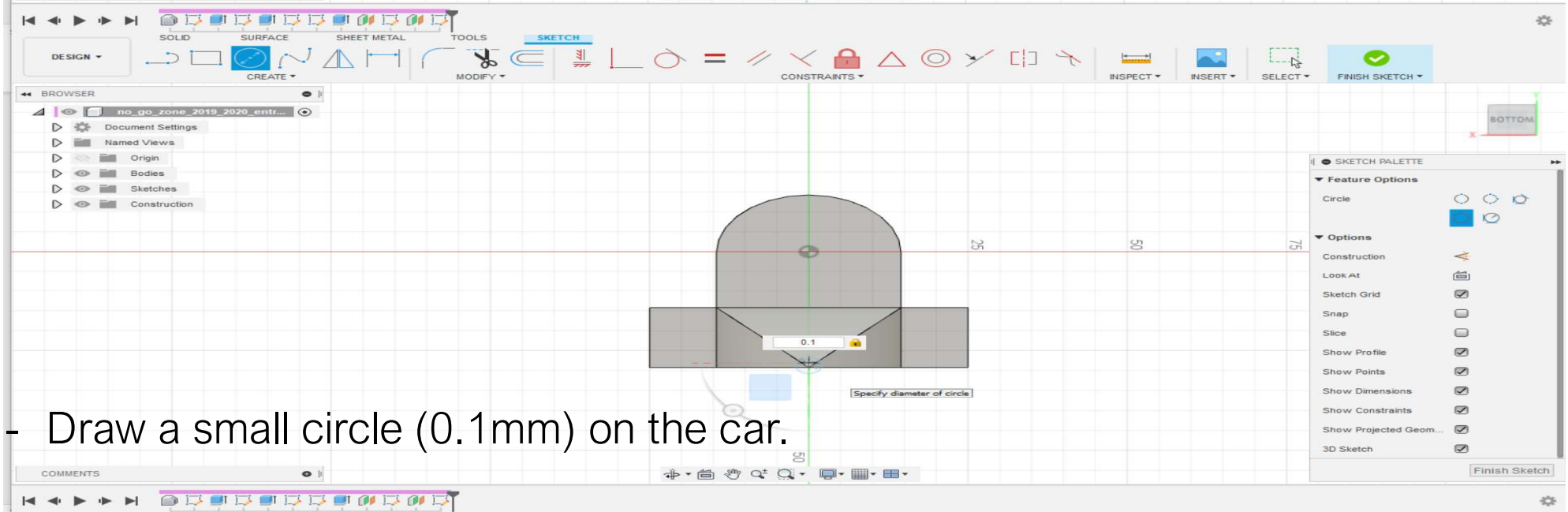
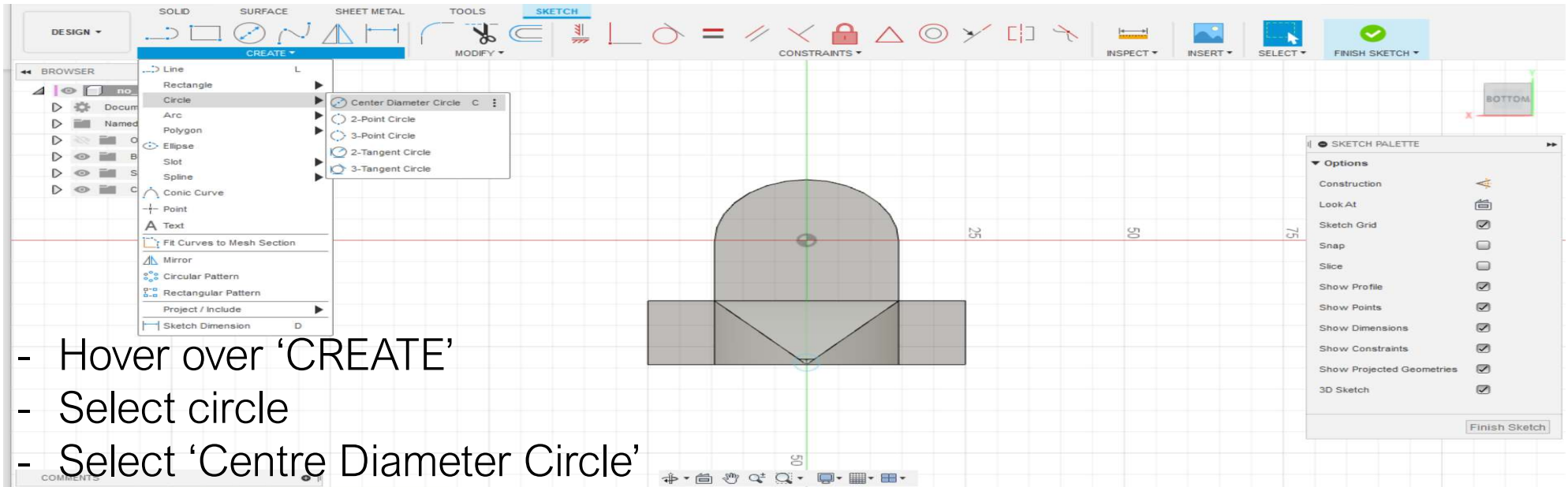

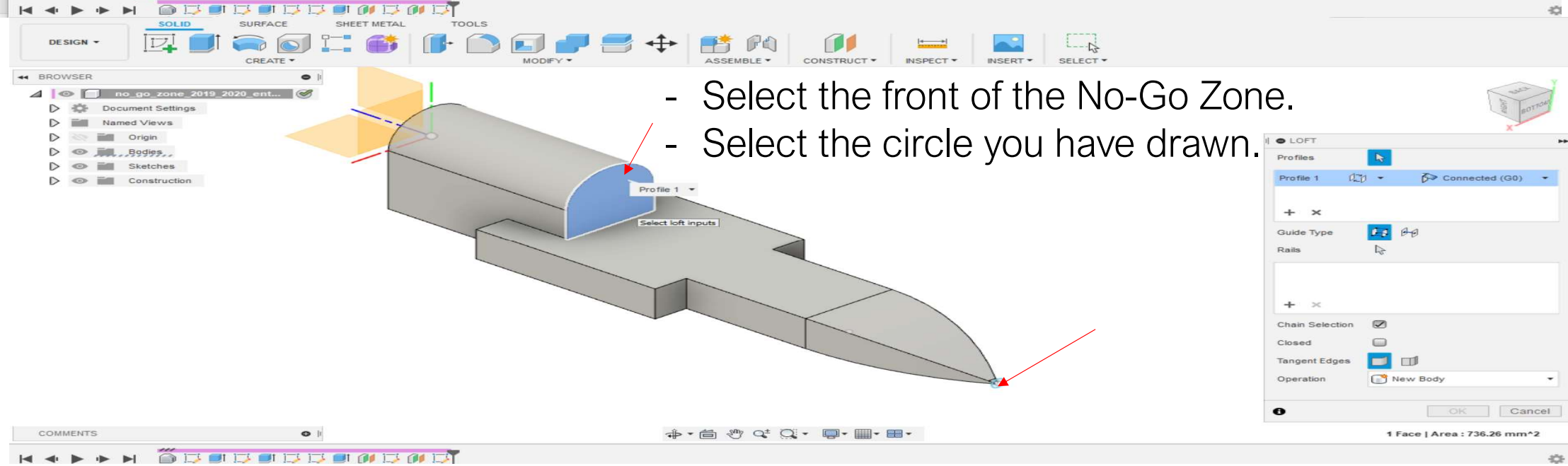
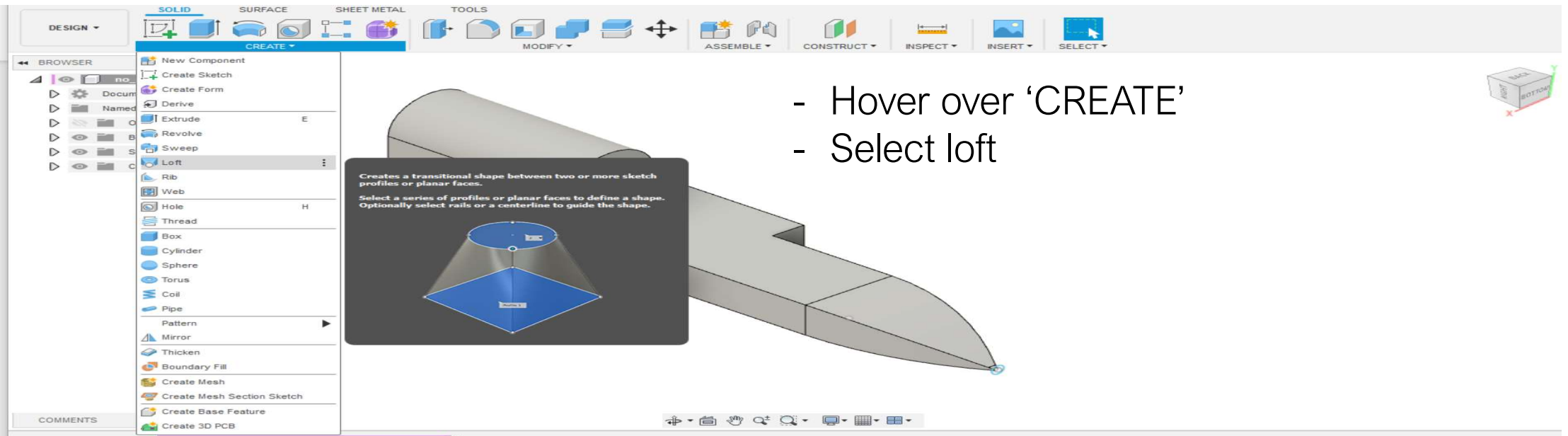

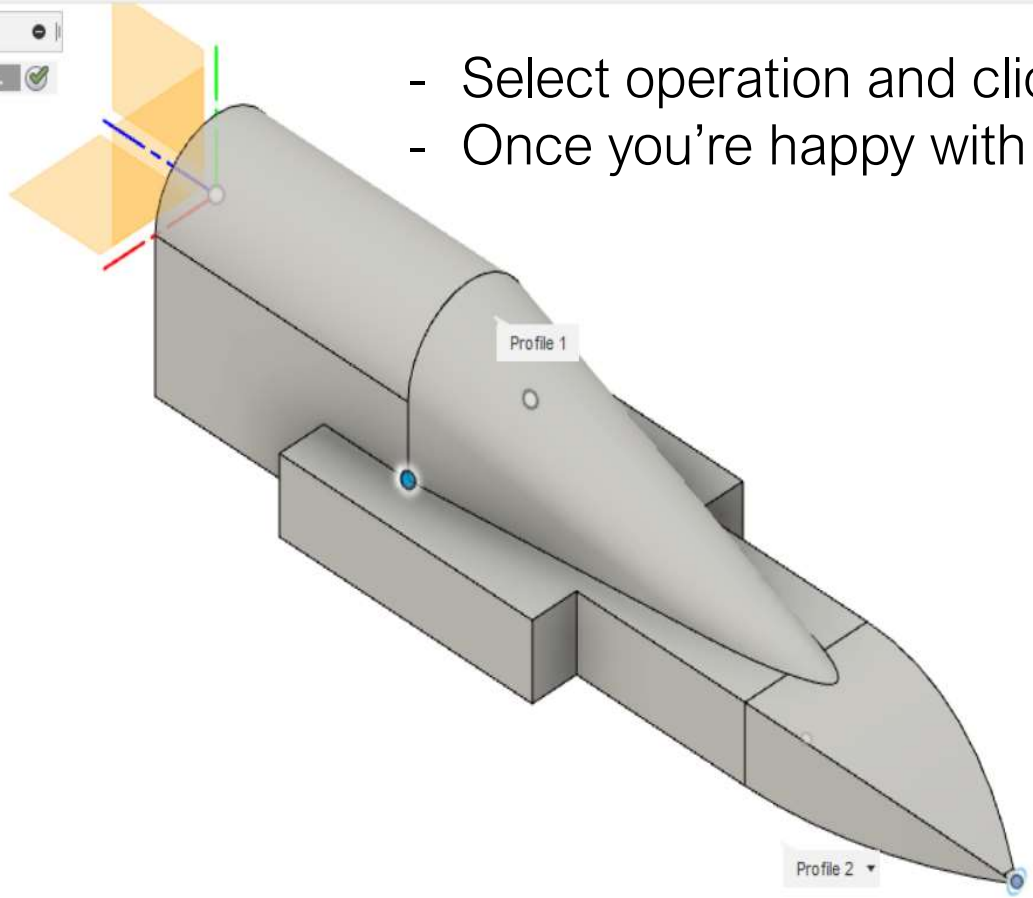
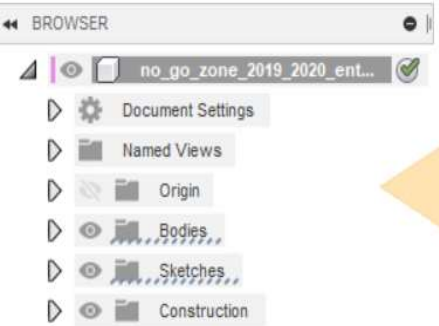

- Select operation and click 'Join'
- Once you're happy with the loft, click 'OK'

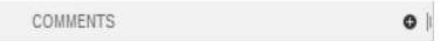
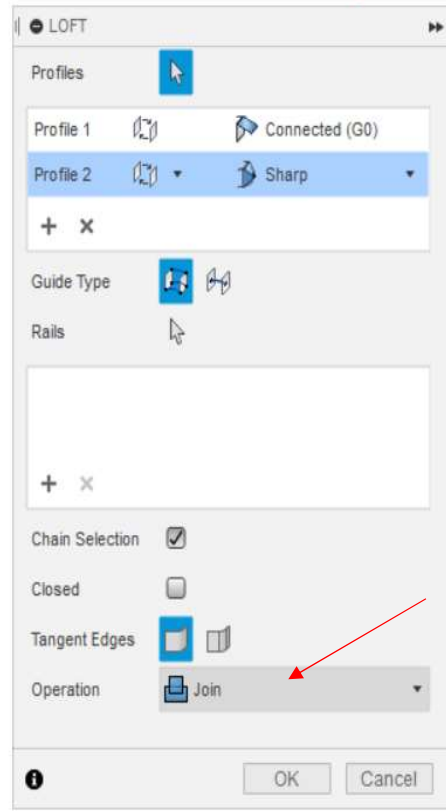

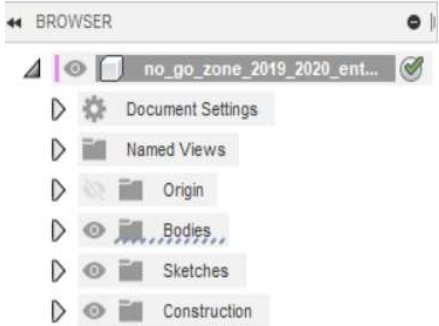

Congratulations, you have create your loft!



If you want to have a different shaped loft, please read on.

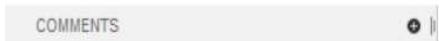
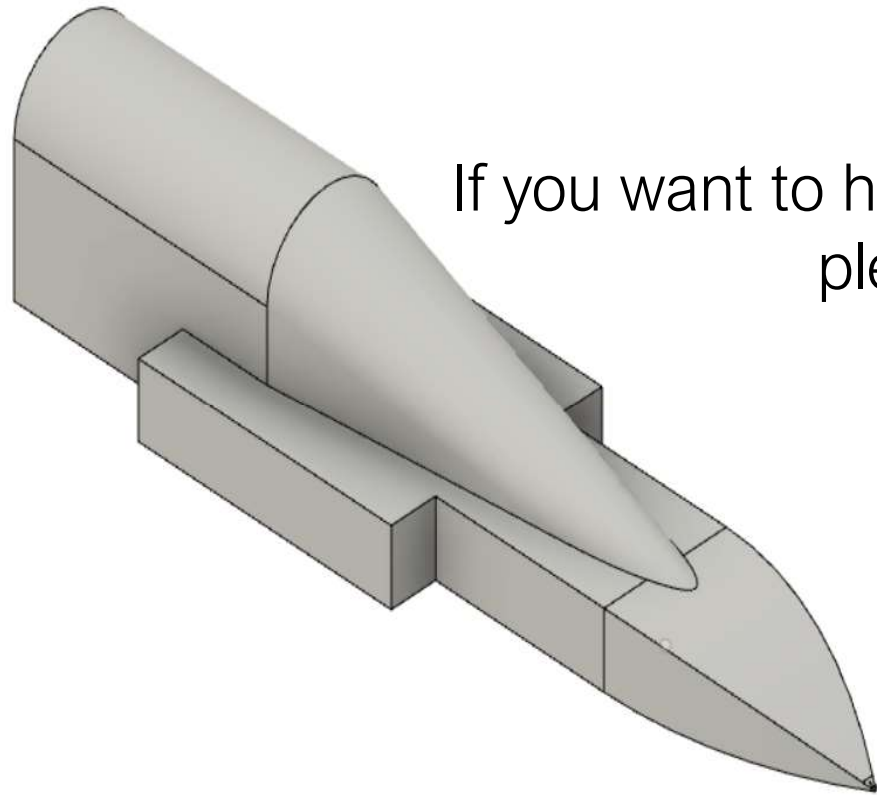

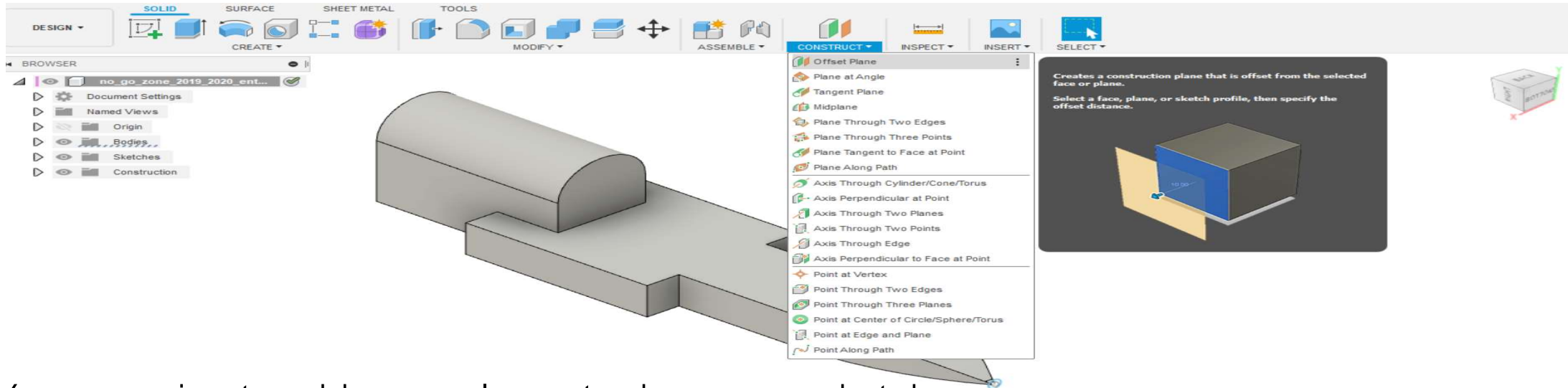

You are going to add more planes to draw more sketches.

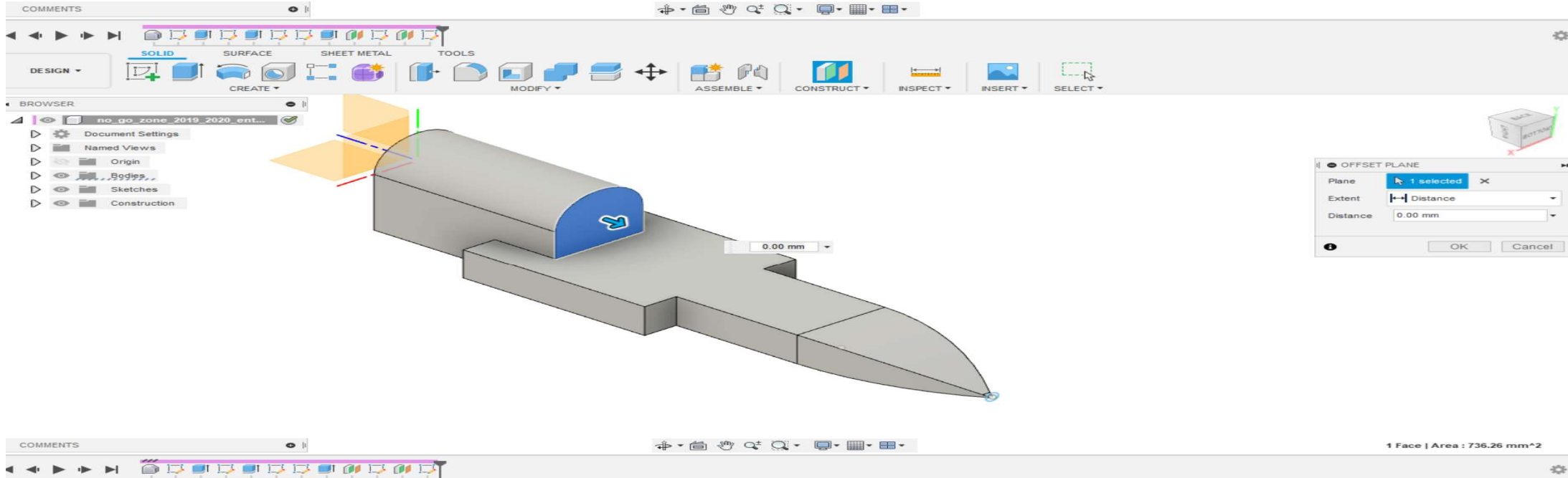

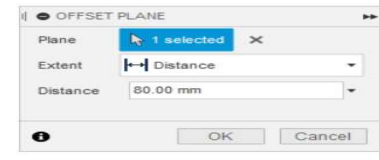
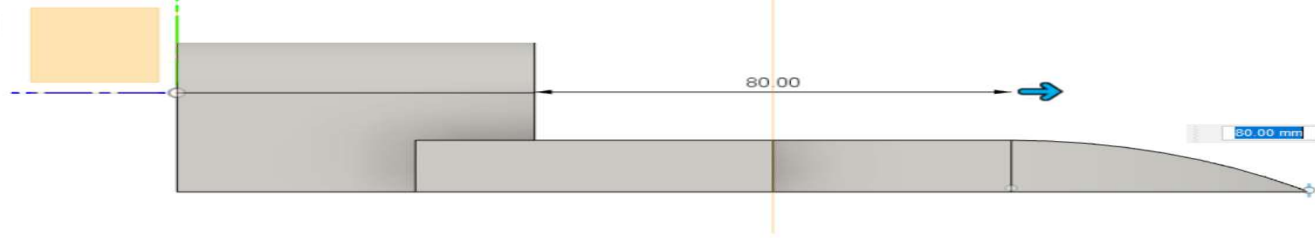
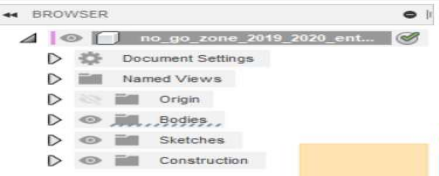
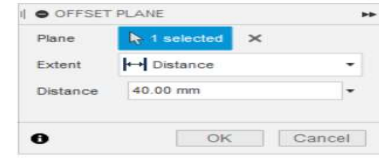
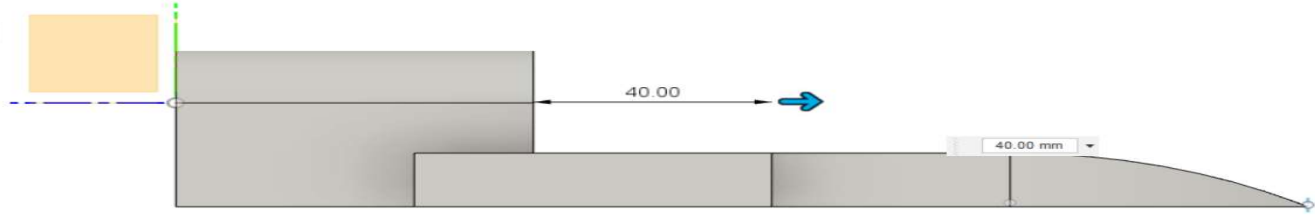
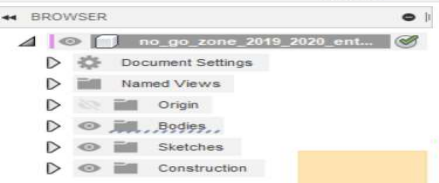

1 Face | Area : 736.26 mm^2

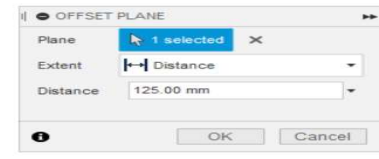
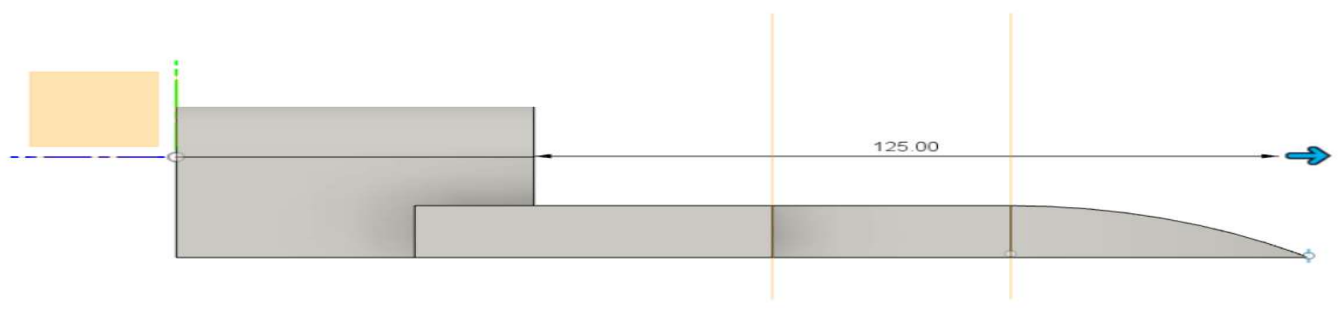
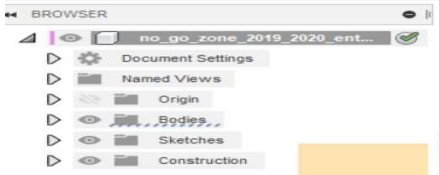

125.00 mm

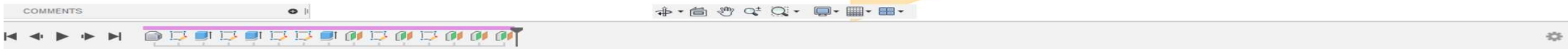
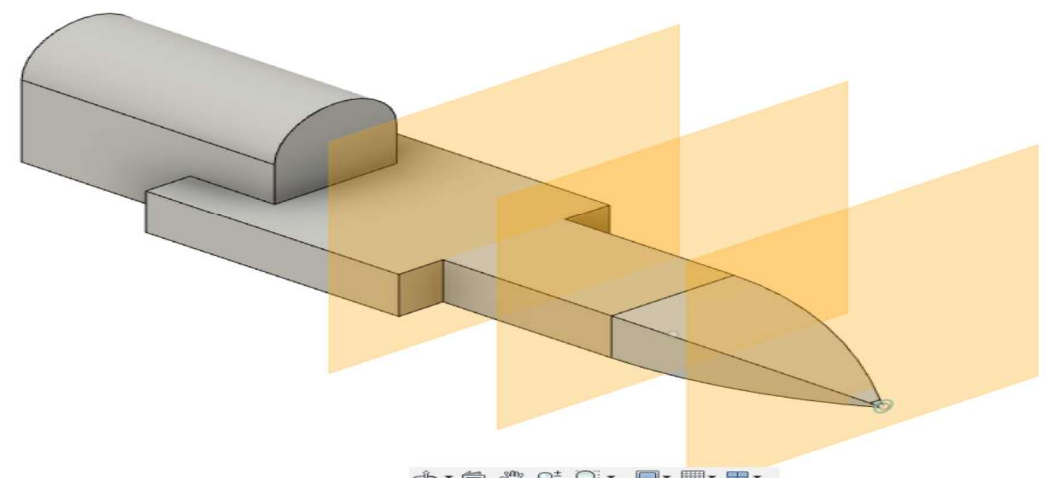
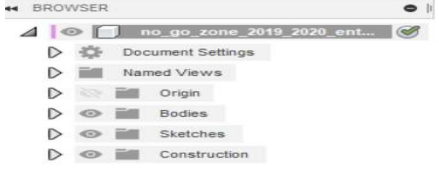

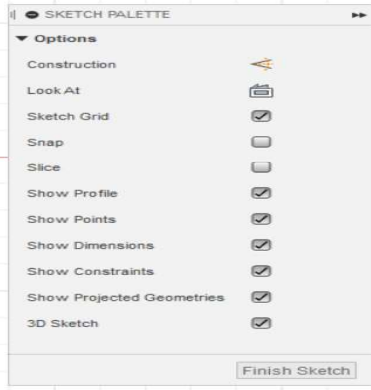
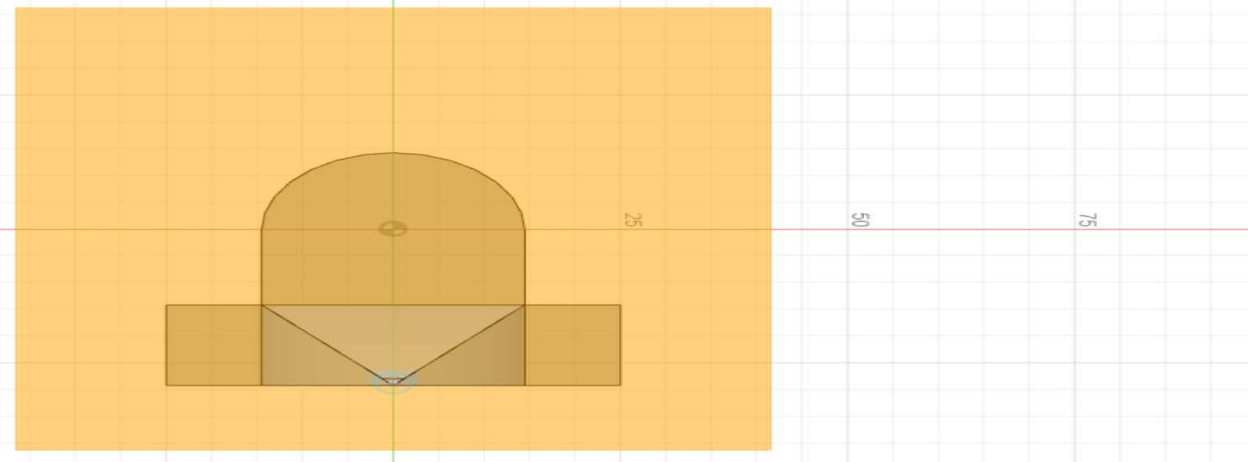
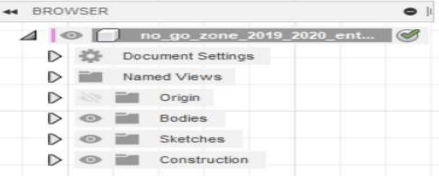
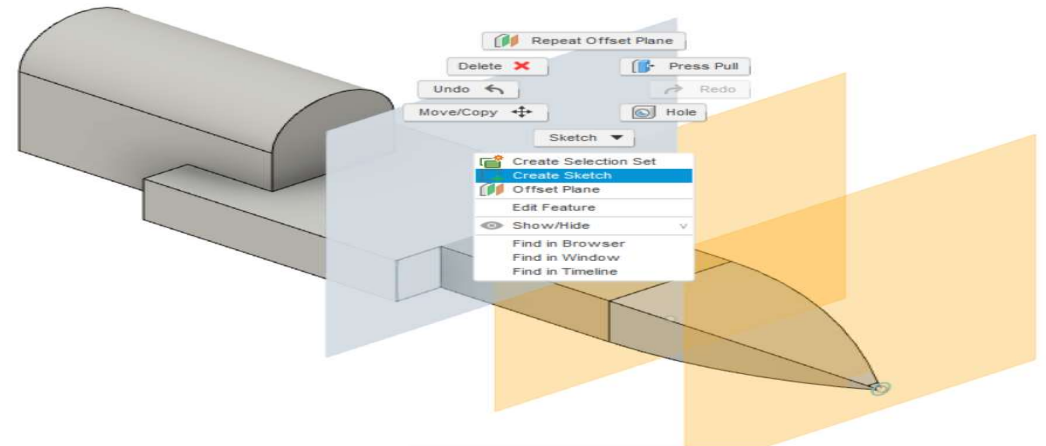
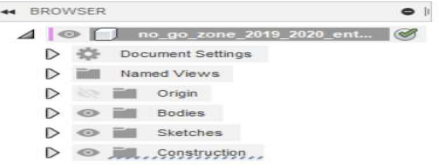

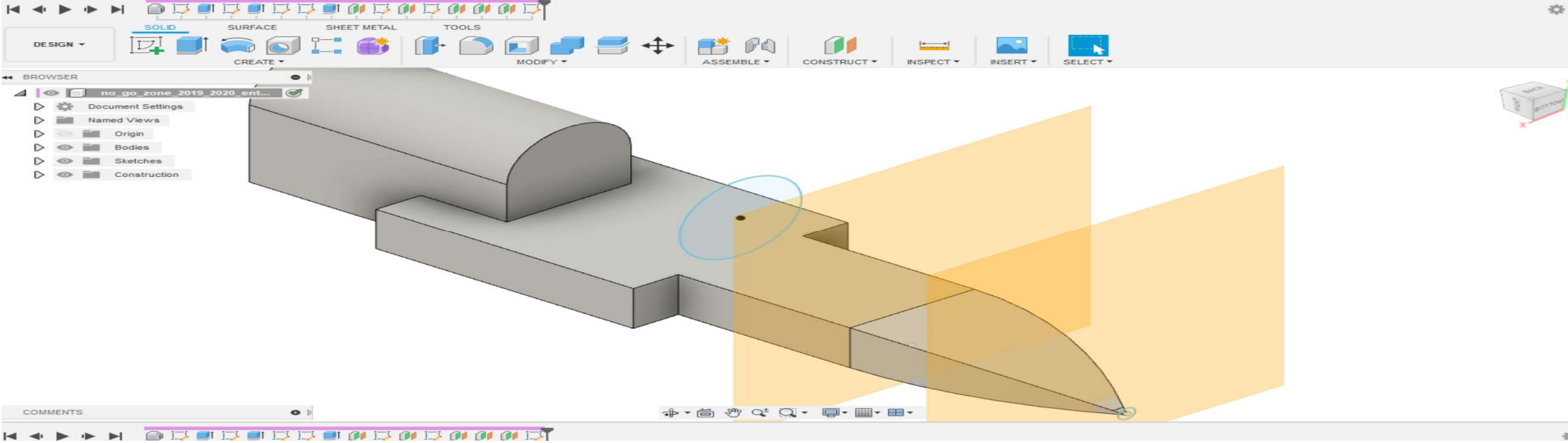
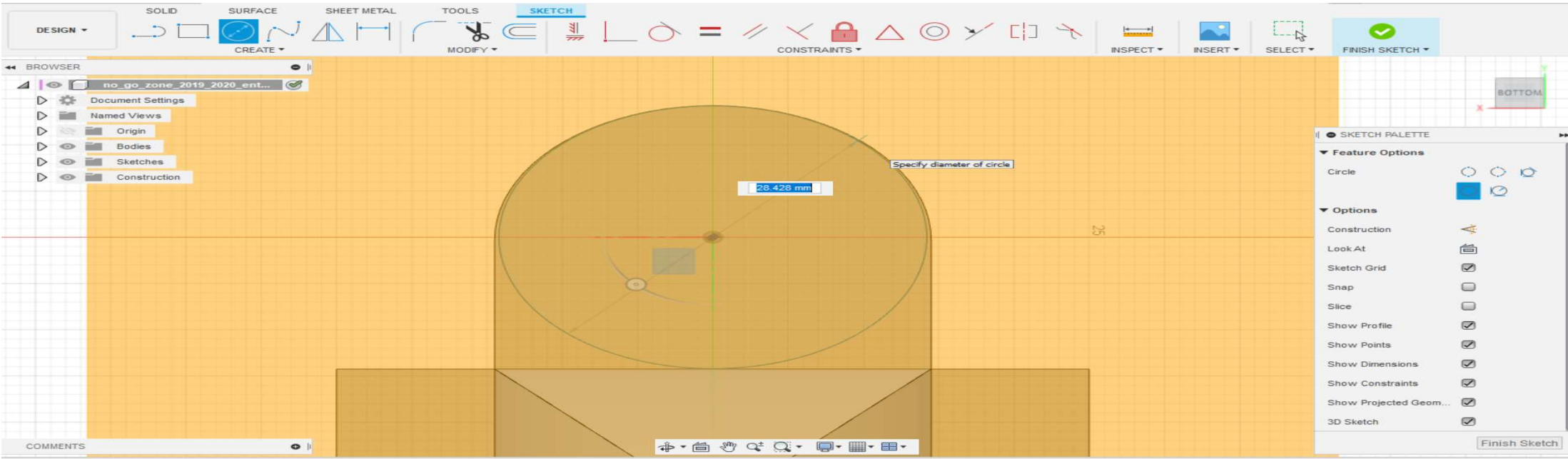

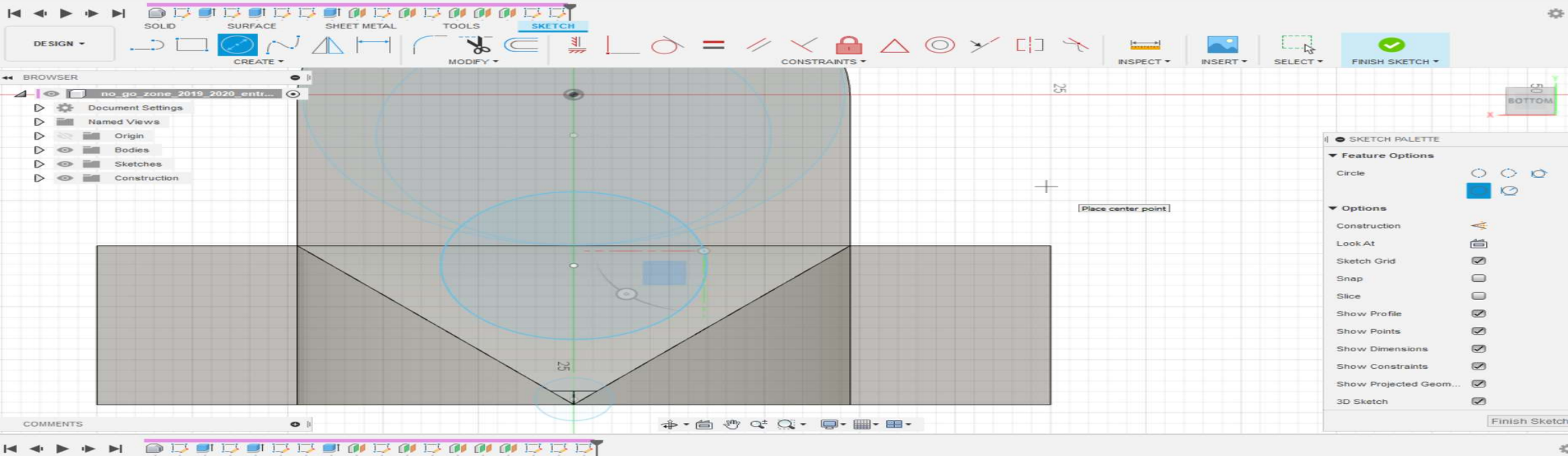
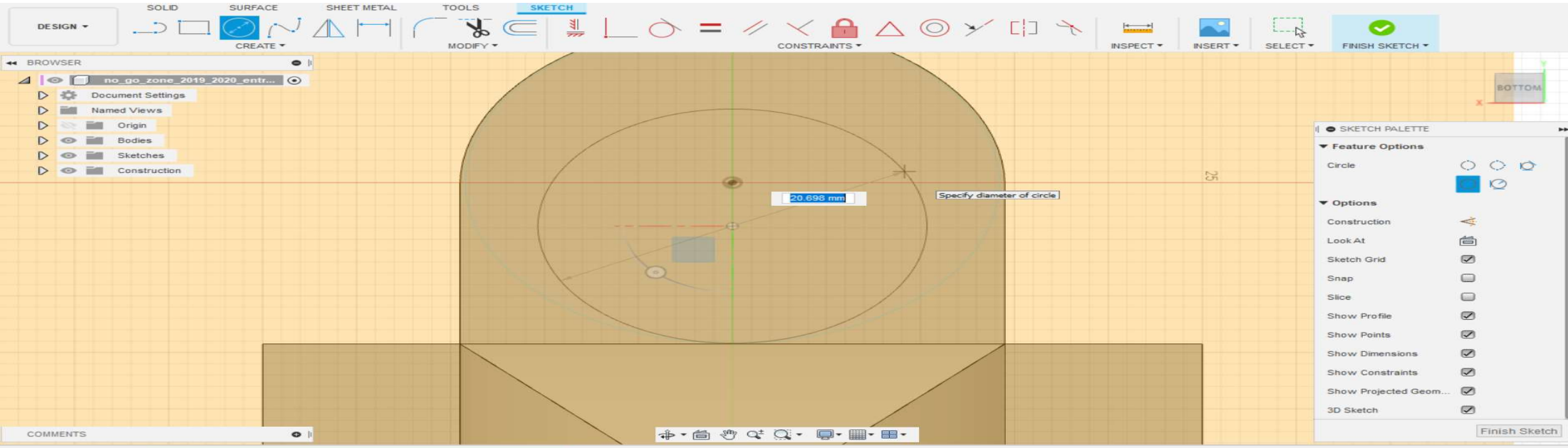

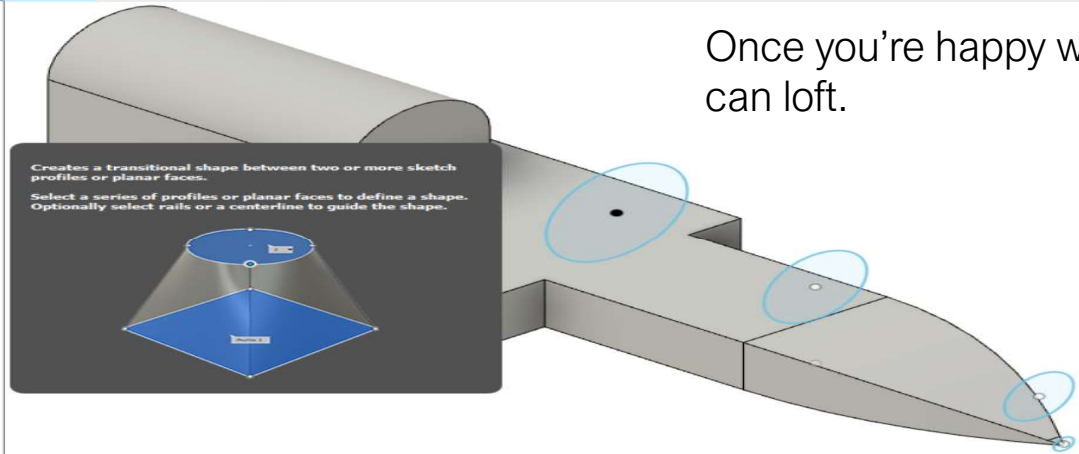
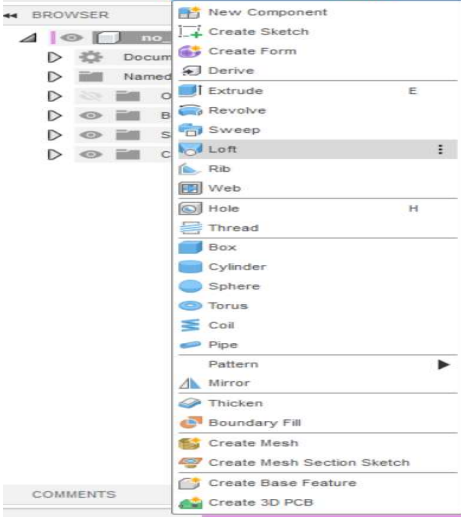
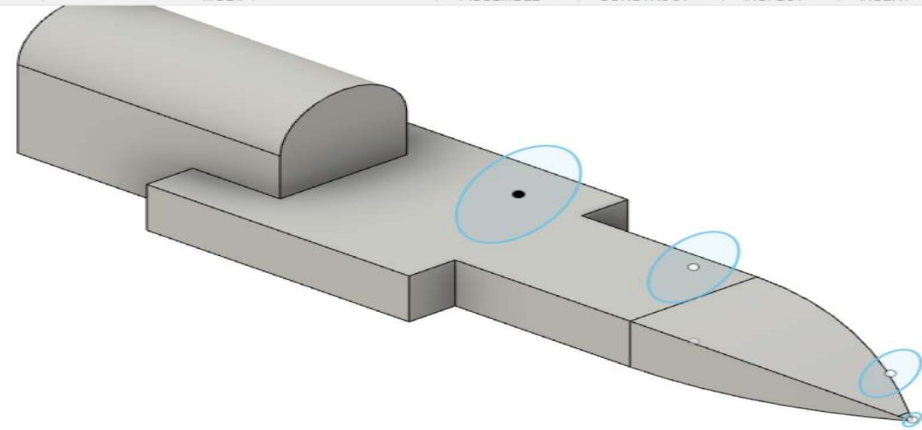
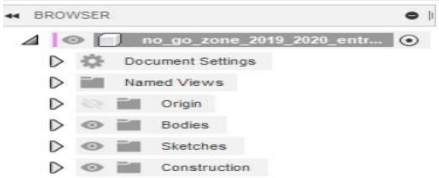

Once you're happy with the shapes you have drawn, you can loft.



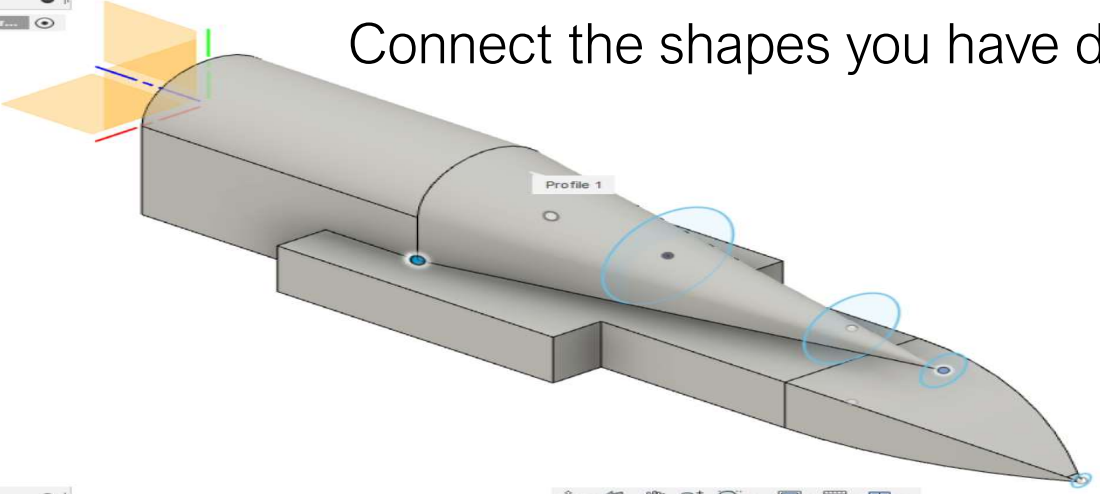
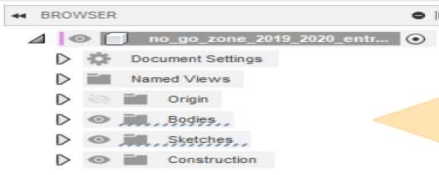

Connect the shapes you have drawn to create your loft.

